



HBF-96 B (Flow-in Pro X)

EXTRACTOR DE ENCIMERA



Campana Datos Técnicos

| | |
|-----------------|--|
| Categoría | Extractor Encimera |
| Dimensión | 85cm |
| Tipo Extracción | Interno (Salida Libre / Recirculacion) |
| Acabado | Inox + Cristal Templado |

Prestaciones

| | |
|---------------------|---|
| Flujo Max | 610 (m ³ /h) |
| Max Nivel Sonoro | 69 dB(A) |
| Absorción Total | 200W |
| Filtros | Filtro de Grasa Negro U Shape + Filtro de Carbón Activo Flexible Opcional |
| Control | 9S+B Multi Slider |
| Iluminación | / |
| Tamaño del Conducto | 220x89 mm |

Encimera Datos Técnicos

| | |
|--------------------------------|--|
| Niveles Potencia | 9 Niveles |
| Booster | 4 Boosters |
| Bridge | Doble |
| Indicador Calor Residual | "H" |
| Mantenimiento Calor | Si |
| Timer | Si |
| Apagado de Seguridad Auto | 90 Min |
| Bloqueo Seguridad | Si |
| Pausa e Inicio | Si |
| Voltaje | 220-240V |
| Frecuencia | 50 / 60Hz |
| Control | Multi Slider |
| Tipo de Bobina | Octa Flex |
| Tamaño y Potencia de la Bobina | 2 (2kW - 2.8kW) - 190*190mm 2 (1,5kW - 2.8kW) - 190*190mm |
| Potencia Total | 7,4 kW |
| Limitación Potencia | 2,8kW - 3,5kW - 7,4kW |

Colores Rejillas



Colores Filtros Grasa

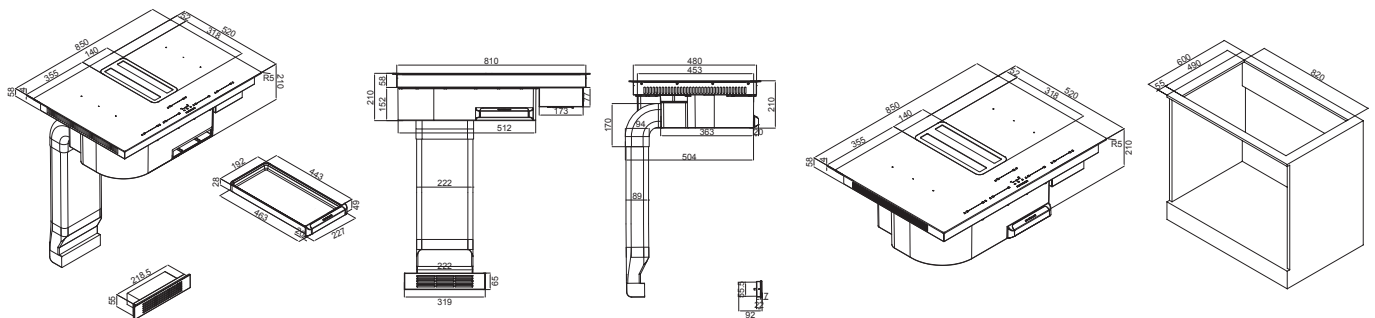

SILVERLINE
www.silverline-home.com

SILVERLINE